

2158425: 7.1 oz CrackleClean™ Sanitizer Dispenser - White
 2158425: Dispensador de desinfectante CrackleClean™ de 7.1 oz - Blanco
 21584254: Distributeur de désinfectant CrackleClean™ de 7.1 oz - Blanc

Accommodates RCP 2158423: 7.1 oz CrackleClean™ Sanitizer Refill
 Compatible con la Repuesto de desinfectante RCP 7.1 oz CrackleClean™
 Convient au réservoir de rechange de désinfectant CrackleClean™ RCP de 7.1 oz

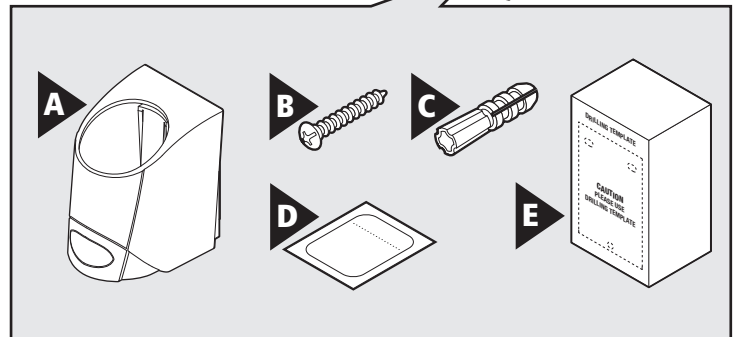
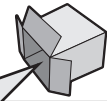

Included | Incluido | Inclus :

A	Dispenser Dispensador Distributeur	1
B	Screw Tornillo Vis	3
C	Anchor for M5 Screw Ancla para tornillo M5 Anclage de la vis M5	3
D	Alcohol Pad Almohadilla con alcohol Tampon d'alcool	1
E	Drilling Template Plantilla de perforación Gabarit de forage	1

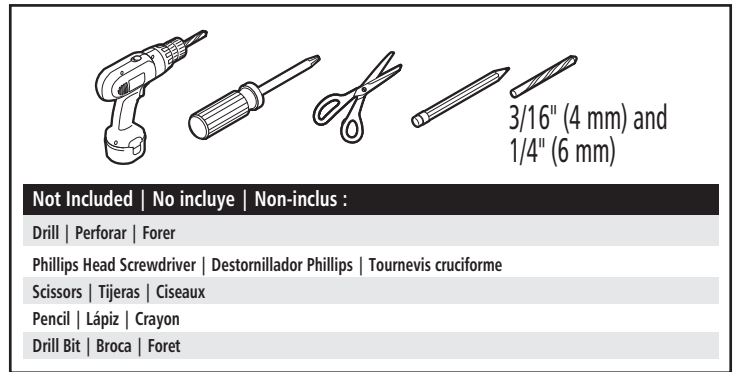

Not Included | No incluye | Non-inclus :

- Drill | Perforar | Forer
- Phillips Head Screwdriver | Destornillador Phillips | Tournevis cruciforme
- Scissors | Tijeras | Ciseaux
- Pencil | Lápiz | Crayon
- Drill Bit | Broca | Foret

Adhesive Mount | Instalación con adhesivo | Embase adhesif

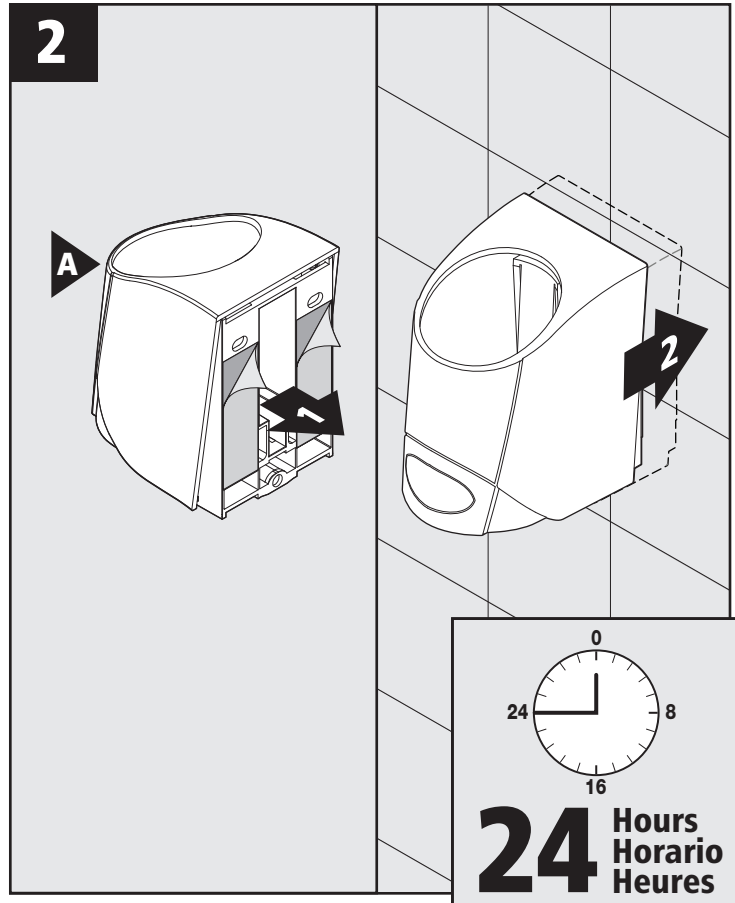
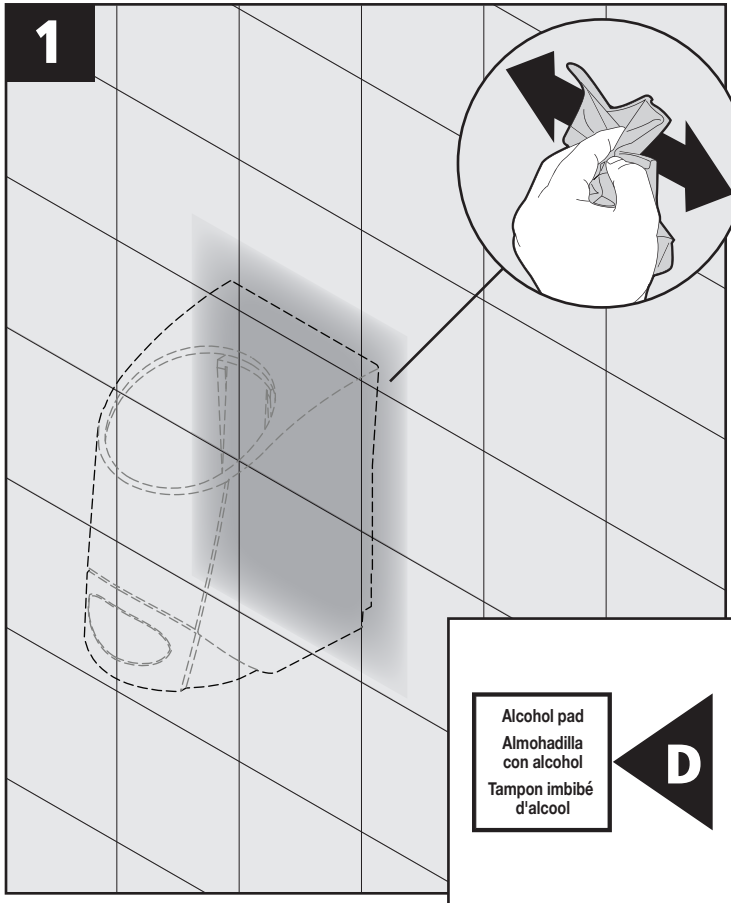

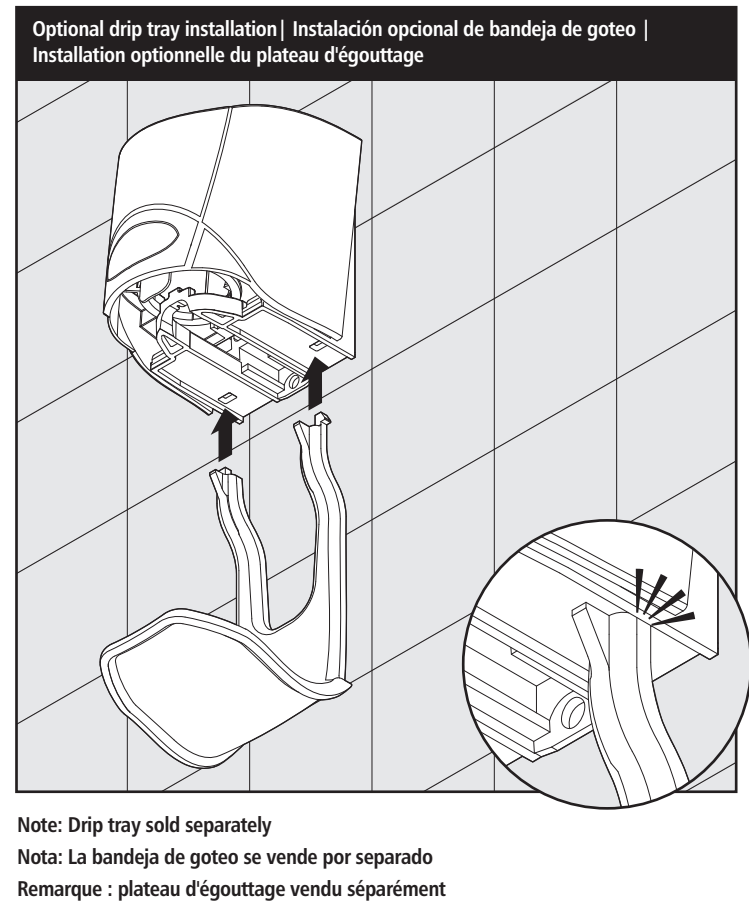
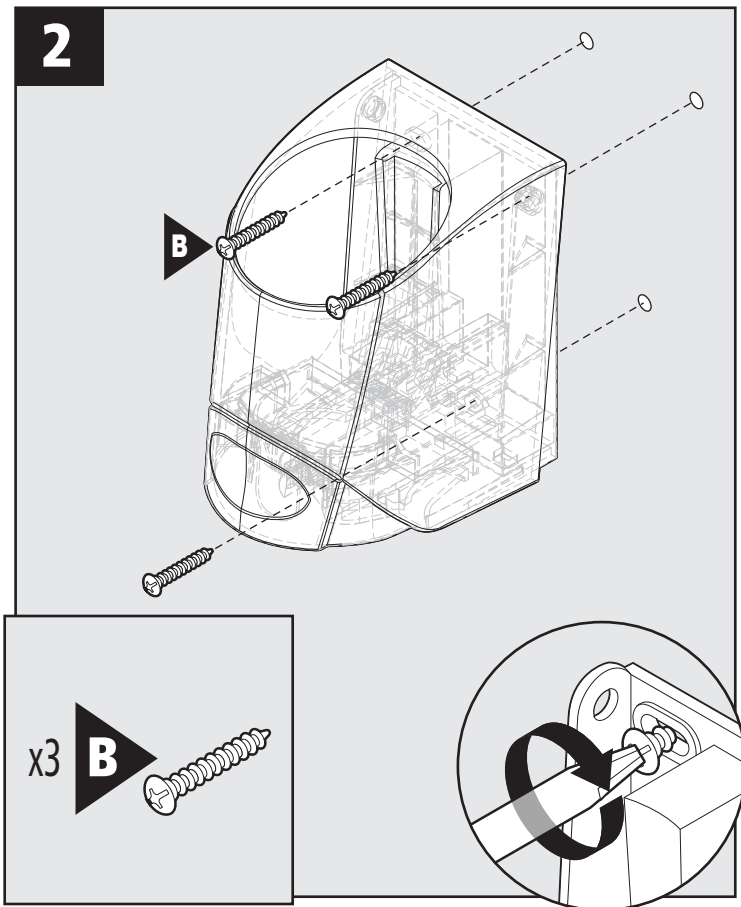
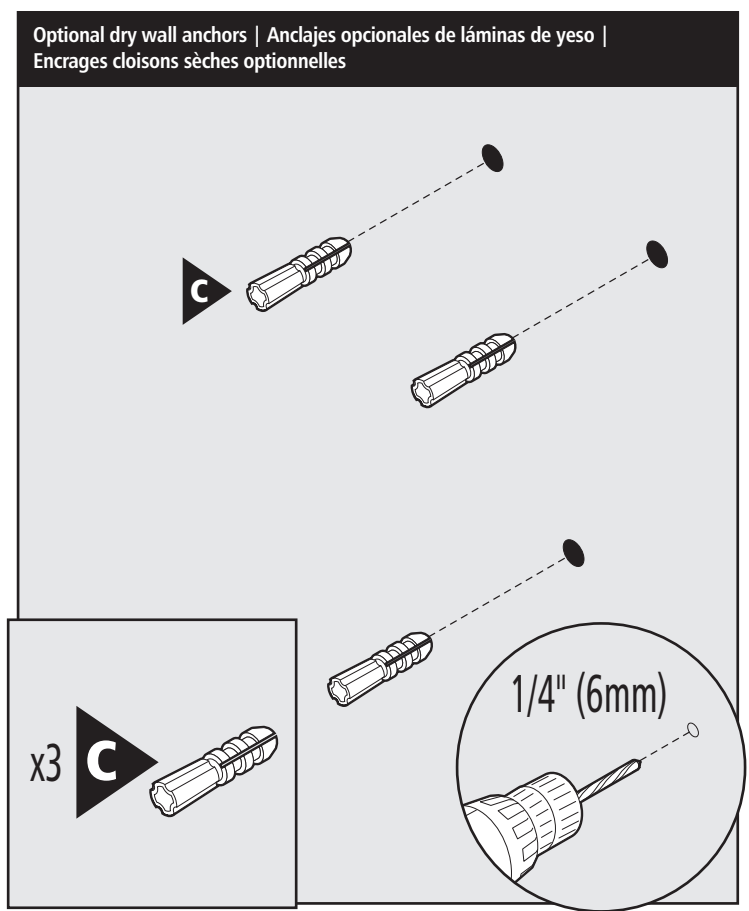
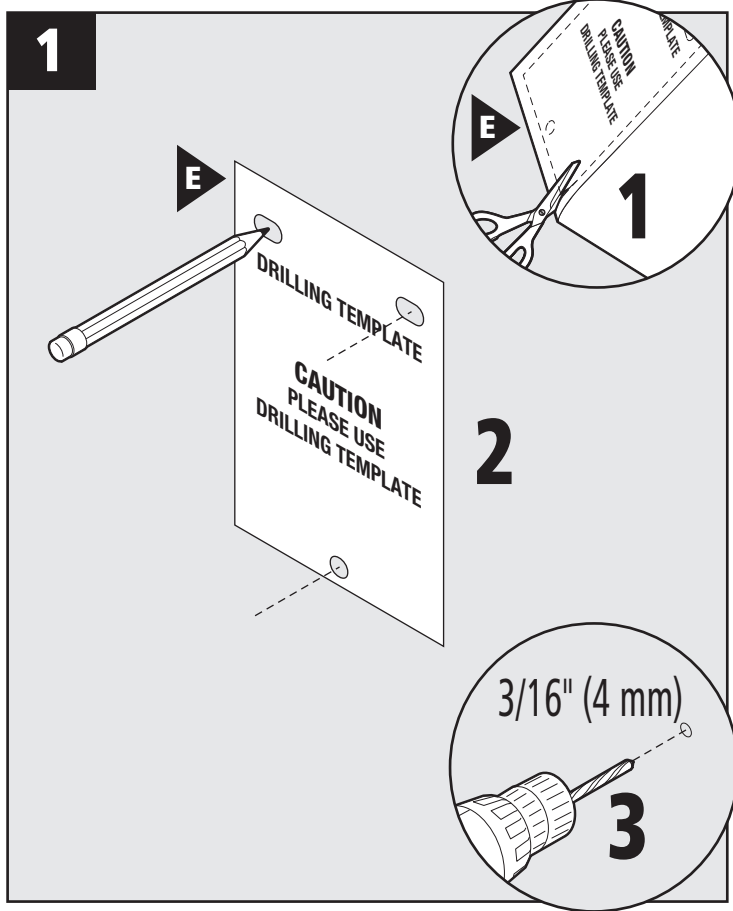

**Install Refill | Instalar repuesto |
Installez le réservoir de recharge**

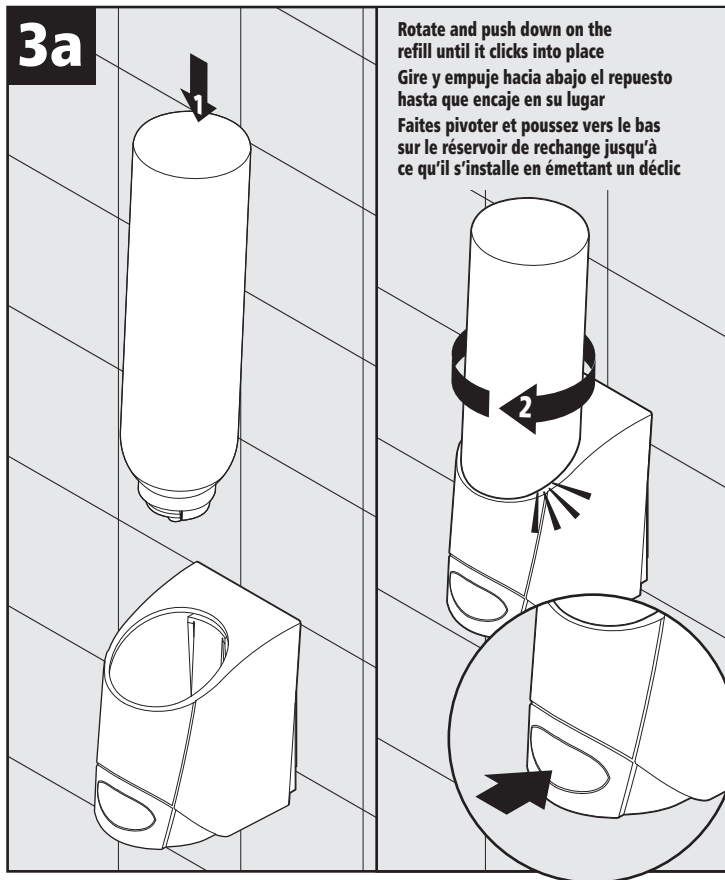

**Remove Refill | Retirar repuesto |
Retirez le réservoir de recharge**

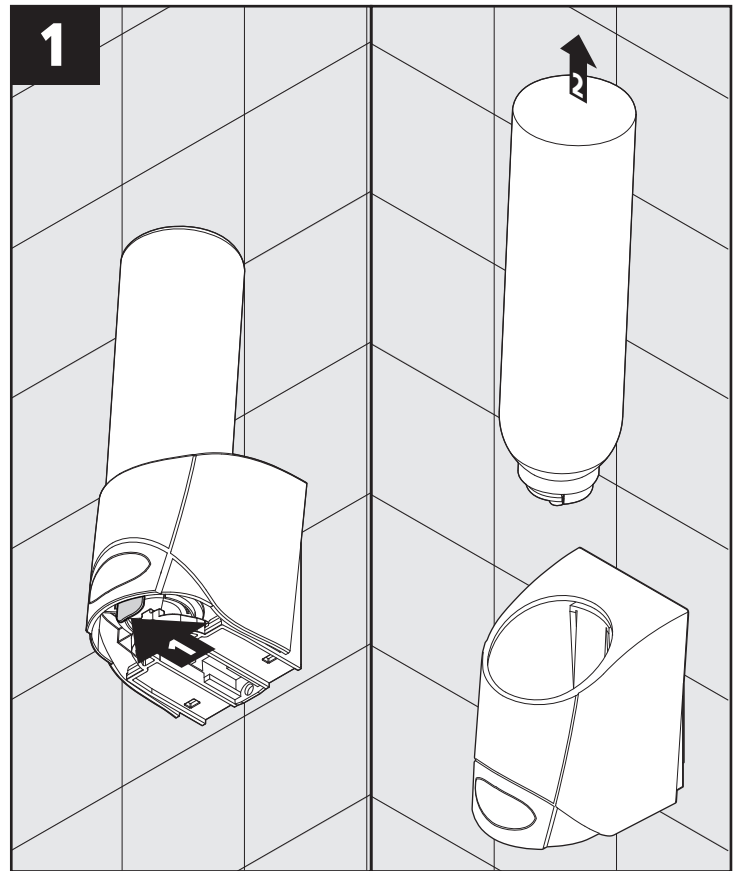

Note: Refill sold separately. Shake can well before installing in dispenser or dispensing onto hands.

Nota: Cada repuesto se vende por separado. Agitar bien la lata antes de colocarla en el dispensador o de distribuirla en las manos.

Remarque : réservoir de recharge vendu séparément. Secouez bien la boîte avant de l'installer dans le distributeur ou d'en distribuer le contenu sur les mains.

