



# RANGER® CONTAINERS

## Features and Benefits:

- Permanently-attached hinged lid allows for easy emptying
- 2-door swing lid or 4-opening lid options available
- Metal retainers keep can liners securely in place and eliminate knot tying
- Modernized colors blend in seamlessly with a variety of spaces
- Built to withstand harsh weather and heavy use with durable, UV-resistant resin
- Made in the USA with global components

## 45 GAL WITH 2 DOORS

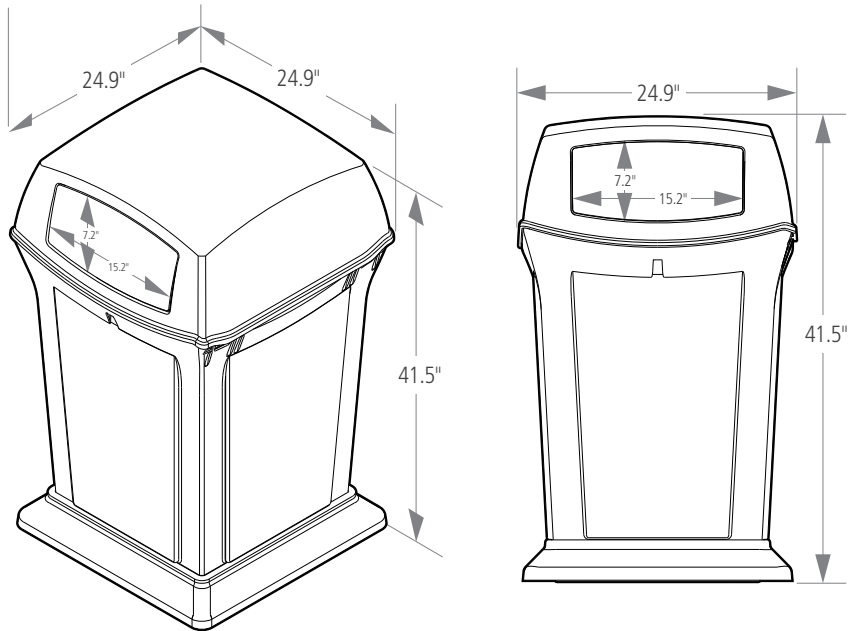

## 35 GAL WITH 2 DOORS

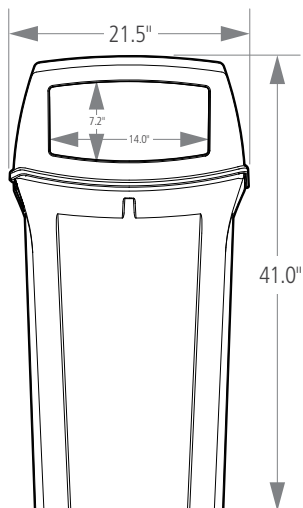
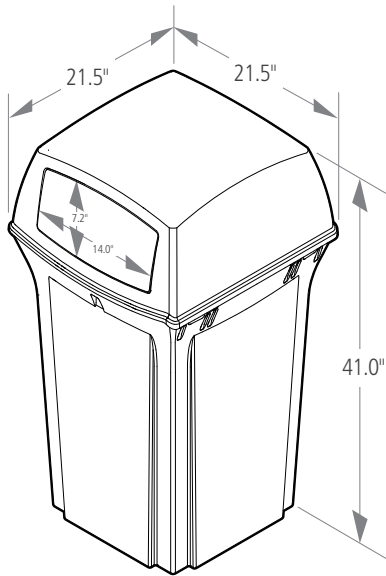

## 45 GAL WITH 4 OPENINGS

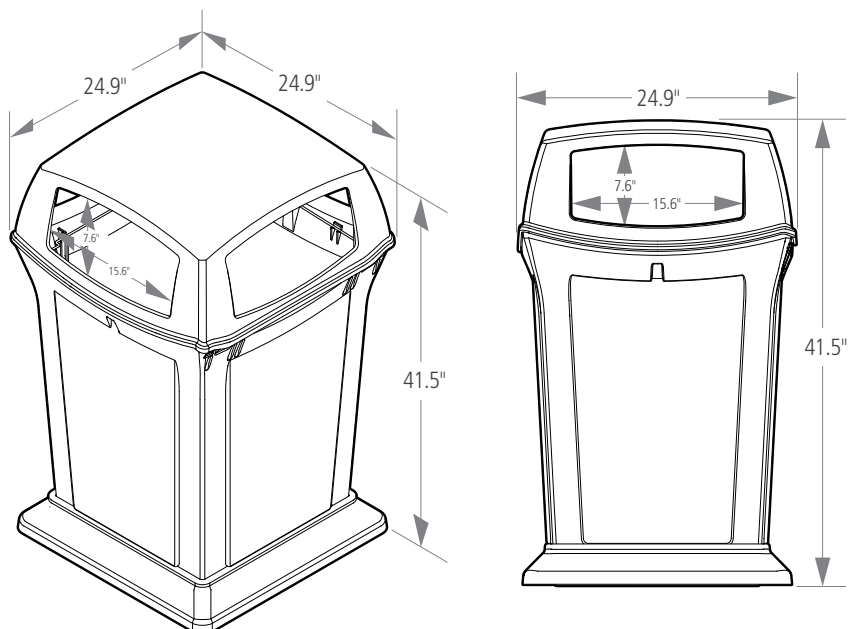

# RANGER® CONTAINERS

NO.	DESCRIPTION	COLOR	CAPACITY
FG843088BEIG	RANGER® CONTAINER WITH 2 DOORS	WOOL	35 GAL
FG843088BLA	RANGER® CONTAINER WITH 2 DOORS	CHARCOAL	35 GAL
FG917188BEIG	RANGER® CONTAINER WITH 2 DOORS	WOOL	45 GAL
FG917188BLA	RANGER® CONTAINER WITH 2 DOORS	CHARCOAL	45 GAL
2234315	RANGER® CONTAINER WITH 2 DOORS, RECYCLING	SOFT SLATE BLUE	45 GAL
FG917388BEIG	RANGER® CONTAINER WITH 4 OPENINGS	WOOL	45 GAL
FG917388BLA	RANGER® CONTAINER WITH 4 OPENINGS	CHARCOAL	45 GAL

